

Magnetic Fuse

Avoid dangerous situations by preventing the spreader from activating the opening system when the interlocking safety pins are **NOT correctly seated** on the container corners.

The BA-350S is a semiautomatic and mechanical fixed spreader for all kind of ISO containers. This TEC model is usually manufactured in 20ft and 40ft but can also be produced in other sizes such 10ft or 45ft.

In the semiautomatic version the twistlocks open and close by means of a mechanism which is activated by the movement up and down of the wire ropes that connect the spreader to the hook of the crane and twistlocks opens and close only if the 4 safety pins, located beside each twistlock, are properly seated on the upper corners of the container.

BA-350S is equipped with high quality components made of the best materials in the market, ensuring its long durability and reliability during its entire life span.

- Safety Interlocking pins to prevent intermediate twistlock positions.
- Mechanical Flag to indicate the position of the twistlocks.
- **Demountable** for easy and affordable transport inside container.
- Modular manufacture for easy interchange of the different parts.
- **Complete CE Certificate.**
- Complete Use & Maintenance Documentation.
- Spare parts kits available permanently in stock.

(*) Other WLL are available under requirement.

TECHNICAL SPECIFICATIONS

- WLL 32t for the 20ft Spreader (*)
- WLL 40t for the 40ft Spreader (*)
- Sizes available 10ft, 20ft, 40ft & 45ft.
- Safety landing pins.
- Complete Structure S355J2+N & Twistlocks F-1252.
- C4 or C5M Painting system.
- Color and logo according to customer's request.

TECHNICAL SPECIFICATIONS OF THE WIRE ROPES

- 2 Sets of 2 Galvanized Wire Rope Slings.
- Length = 8200mm (40ft)
- Length = 4500mm (20ft)
- Safety Factor = 1:5
- Wires according to norm EN-13414-1.

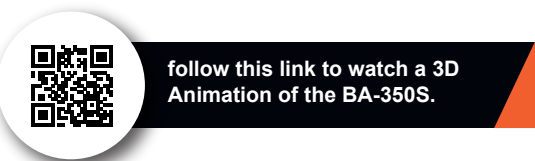

Specifications may vary. Contact TEC CONTAINER for further clarifications.

WLL = 32t or 36t (20ft Spreader)
WLL = 40t (40ft Spreader)

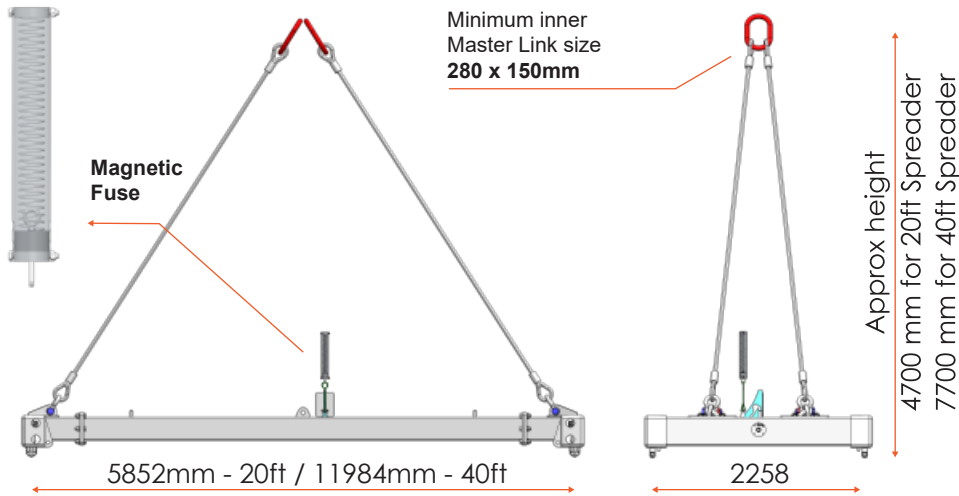

follow this link to watch a 3D Animation of the BA-350S.

STRENGTHS

- **Twistlocks:** Spanish forging, with heat treatment, full traceability and load testing.
- **Modular construction:** The sort sides and the central body can be replaced by an identical part in case of damage, hit or bent.
- **Delivered inside a 40ft HC Container** reducing transport costs.



BENEFITS

- Floating Twistlocks to ease the approach to the container.
- Twistlocks are removable and very easy to substitute.
- Heavy reinforced on the corners.
- Very easy use.
- Very easy maintenance.

OPTIONS

- Long term Galvanized Protection.
- Forklift Pockets (for empty use only)
- Extension Chains (for damage or deformed containers)
- Guides / Flippers.
- 3rd Party loading tests and inspection.
- Wheels for Cell Guides.
- Cycle counter.

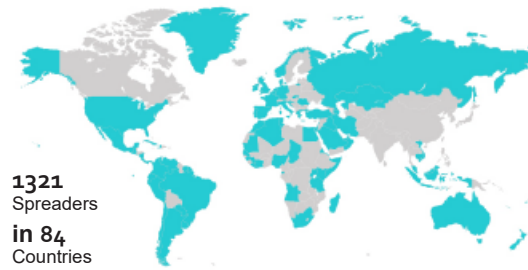

1321
 Spreaders
in 84
 Countries
 Since 2010

MANUFACTURED ACCORDING:

- EUROPEAN MANICHERY DIRECTIVE 2006/42/CE
- EN 13155:2004+a2:2009
- EUROPEAN DIRECTIVE: 2007/95/CE



For more information, spare parts or prices, please check our web: containerspreaders.com

